

# Thermochemistry

## Chapter 5

*No Calculators*

# Both of these sketches are called an *Energy Diagrams*

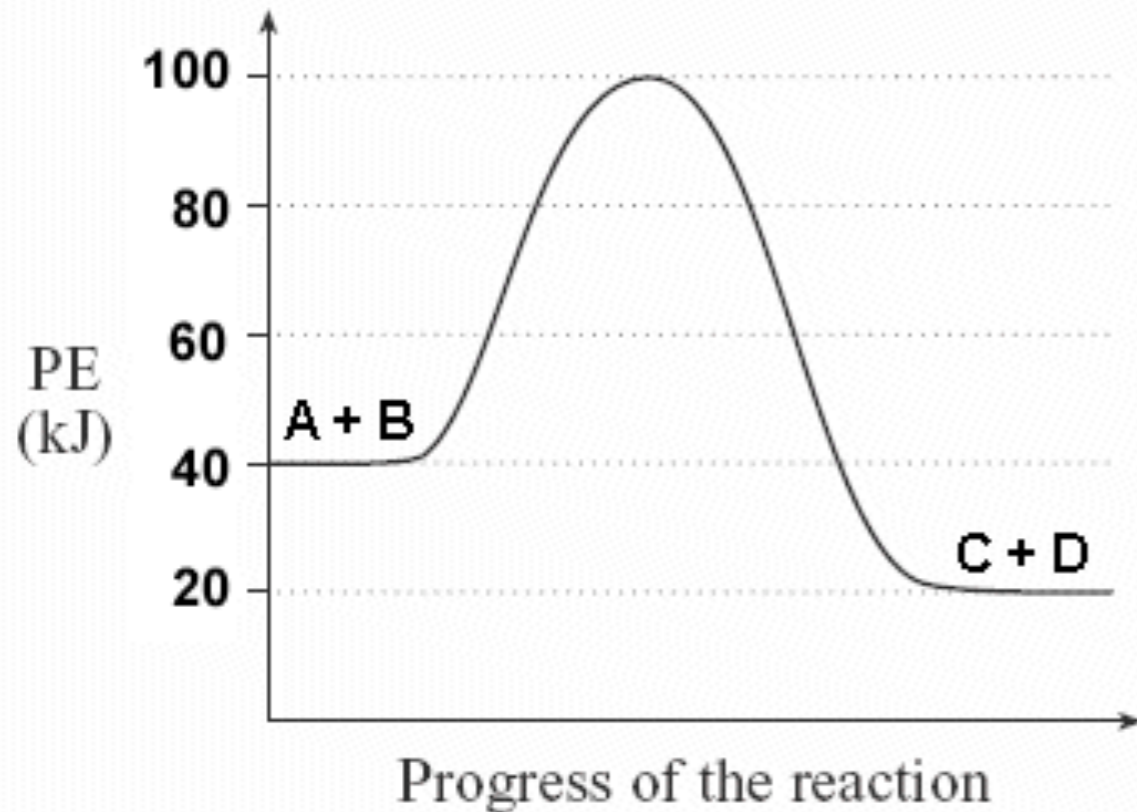

The AP Exam sometimes refers to them as a *Potential Energy Diagrams*

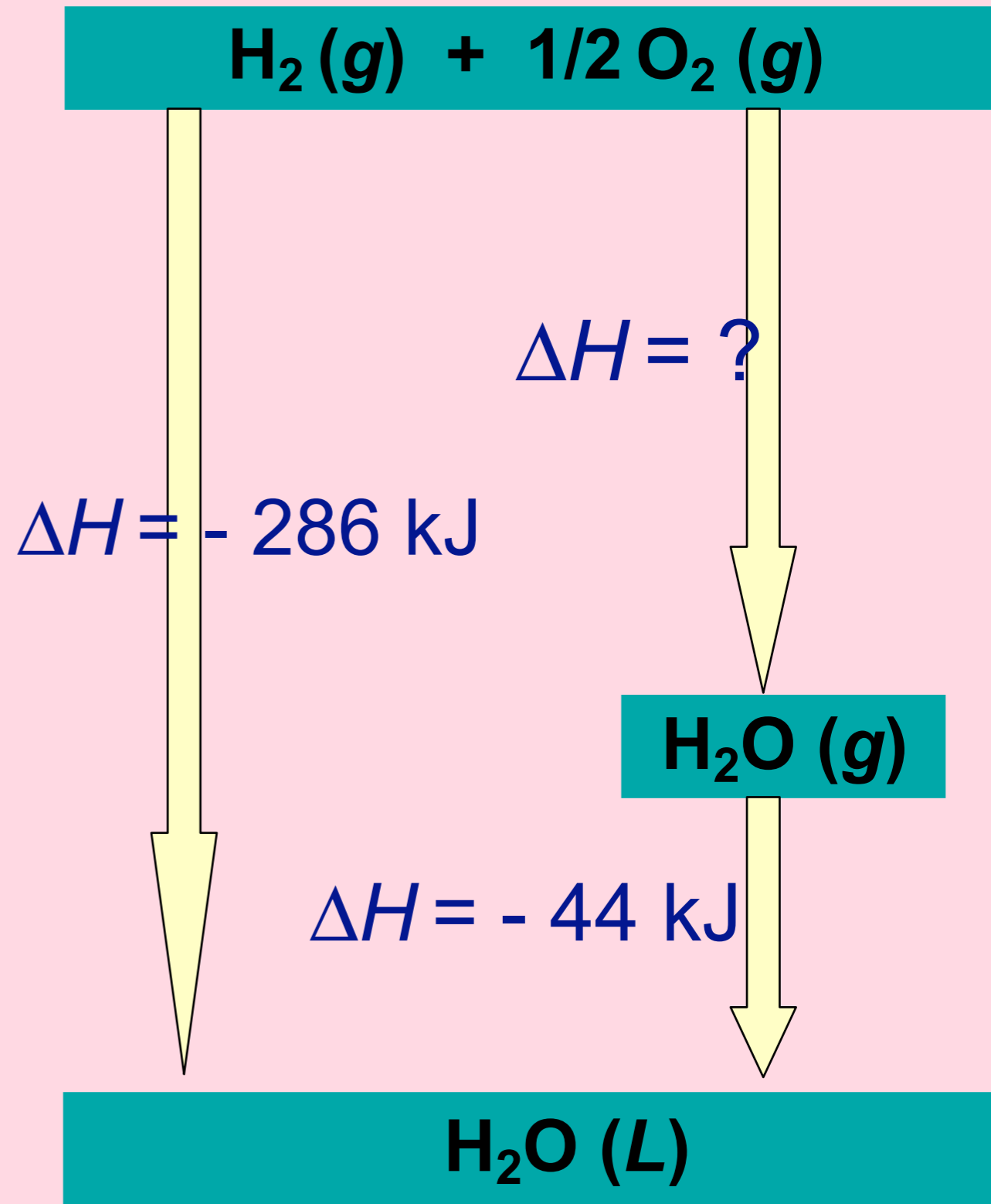

What is the value of the unknown  $\Delta H$  in the energy diagram below?

1. +330 kJ
2. -330 kJ
3. +286 kJ
4. -242 kJ
5. +242 kJ

$\Delta H = -286 \text{ kJ}$

$\Delta H = ?$

$\Delta H = -44 \text{ kJ}$

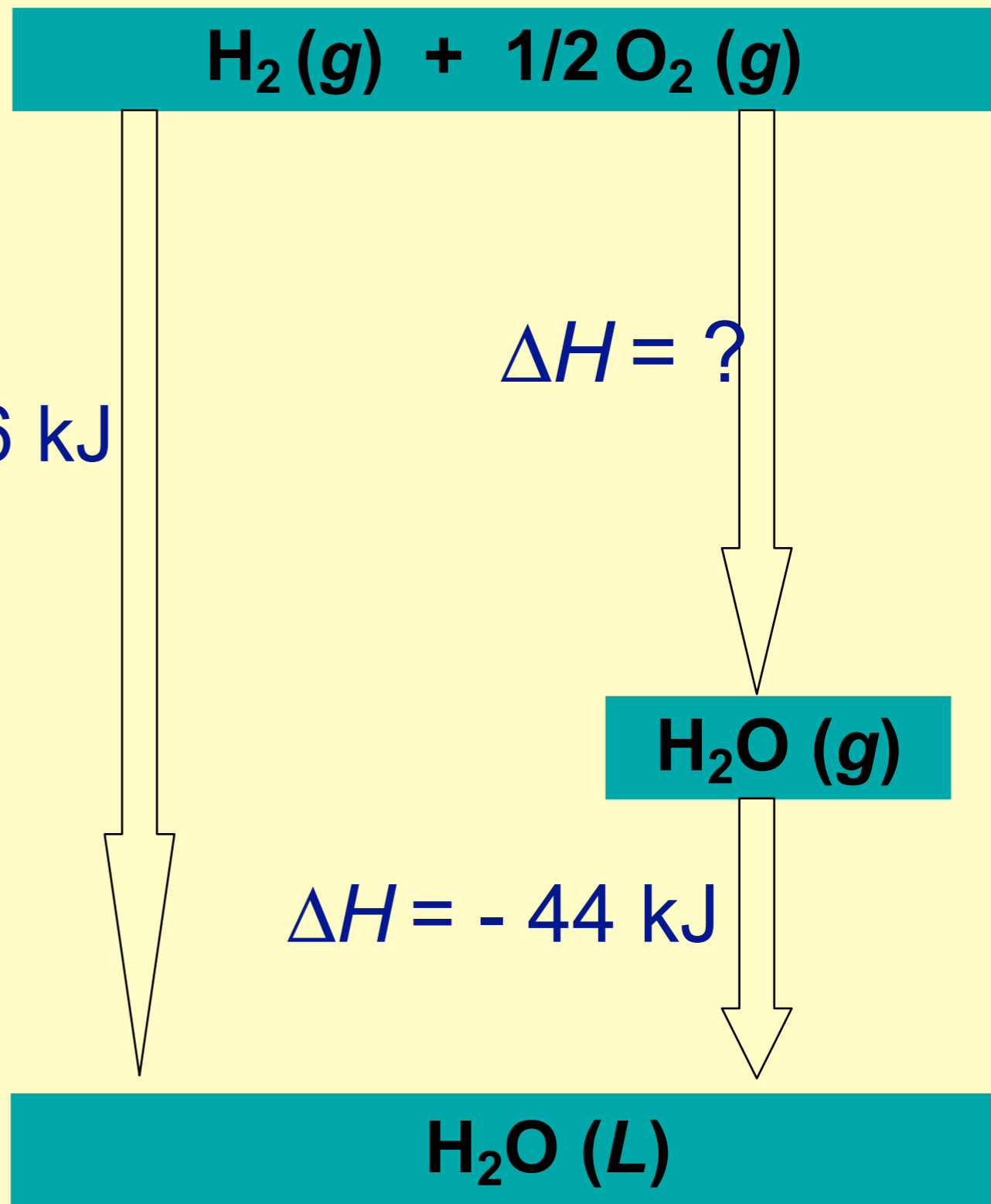

What is the value of the unknown  $\Delta H$  in the energy diagram below?

1. +330 kJ
2. -330 kJ
3. +286 kJ
4. -242 kJ
5. +242 kJ

$$\Delta H = -286 \text{ kJ}$$



$$\Delta H = ?$$



$$\Delta H = -44 \text{ kJ}$$



In a chemical reaction, the difference between the potential energy of the products and the potential energy of the reactants is defined as

1. activation energy
2. ionization energy
3. heat of vaporization
4. heat of reaction
5. kinetic energy
6. lattice energy

In a chemical reaction, the difference between the potential energy of the products and the potential energy of the reactants is defined as

1. activation energy
2. ionization energy
3. heat of vaporization
4. heat of reaction,  $\Delta H$
5. kinetic energy
6. lattice energy

Which number in the potential energy diagram shown below, represents the heat of the reaction,  $\Delta H$ ?

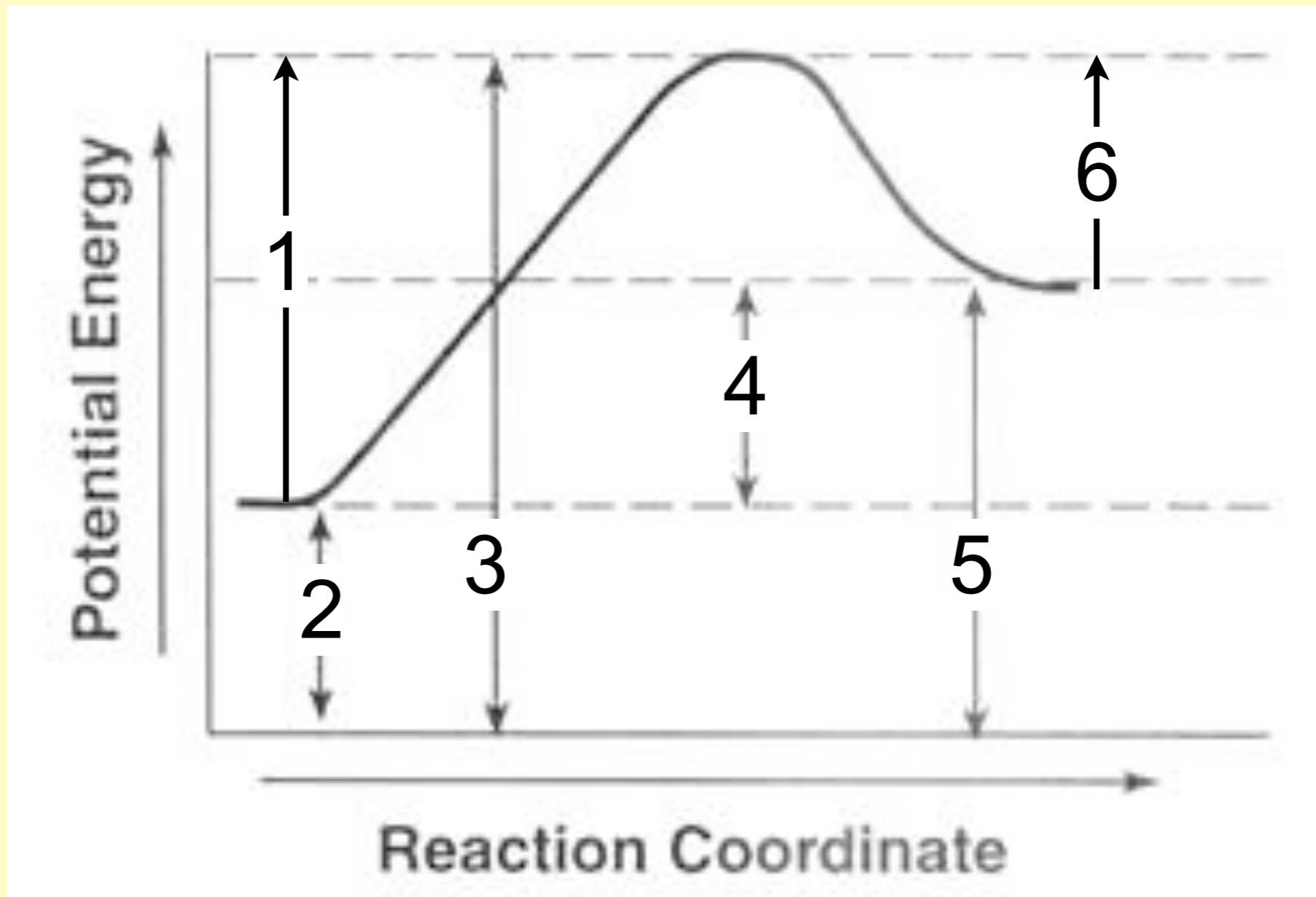

Which letter in the potential energy diagram shown below, represents the heat of the reaction,  $\Delta H$ ?

- $\Delta H$  represents the “net” energy difference between the reactants and the products

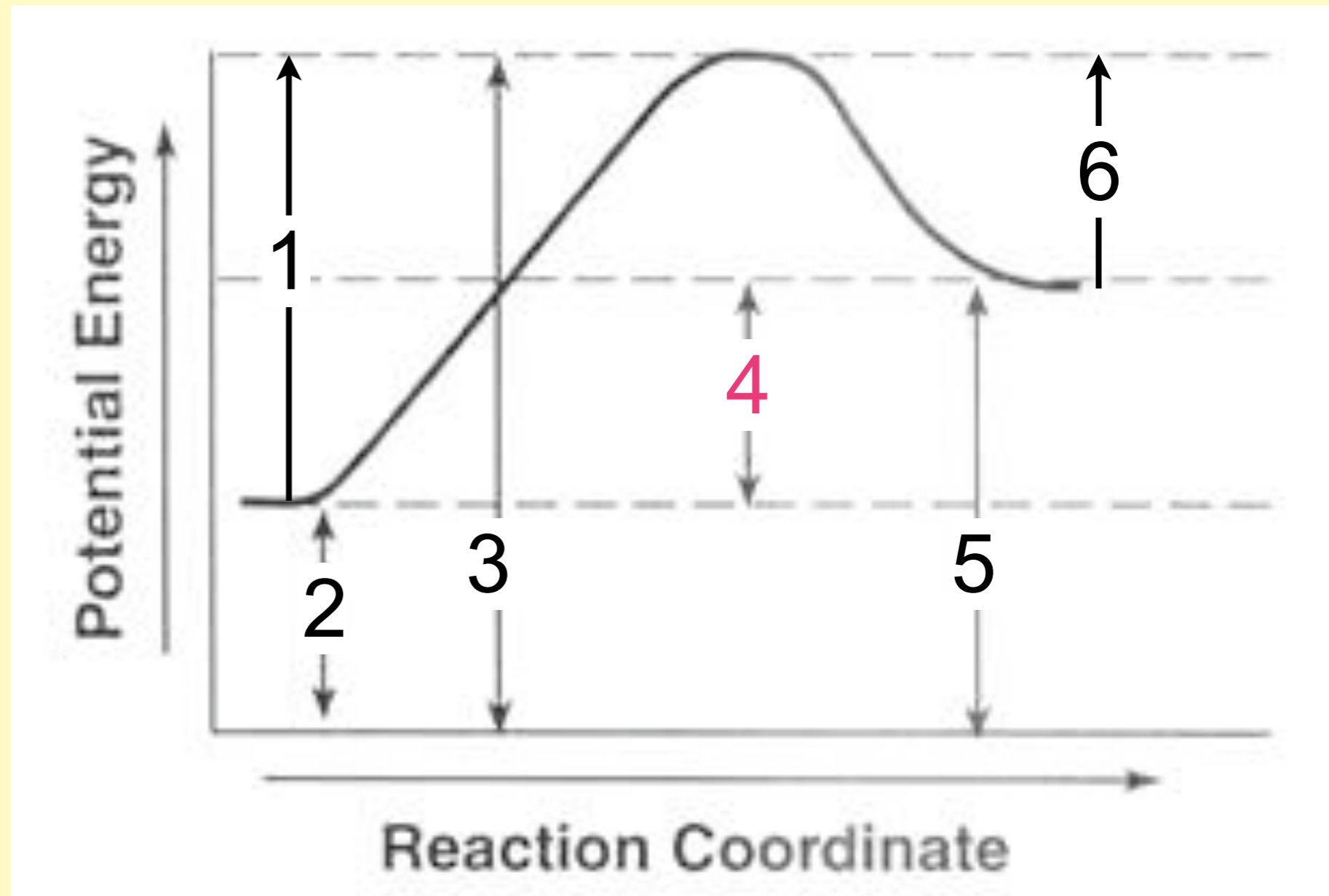

# The reaction represented by this graph

1. is exothermic
2. is endothermic
3. There is not enough information to determine the energetics of this reaction.

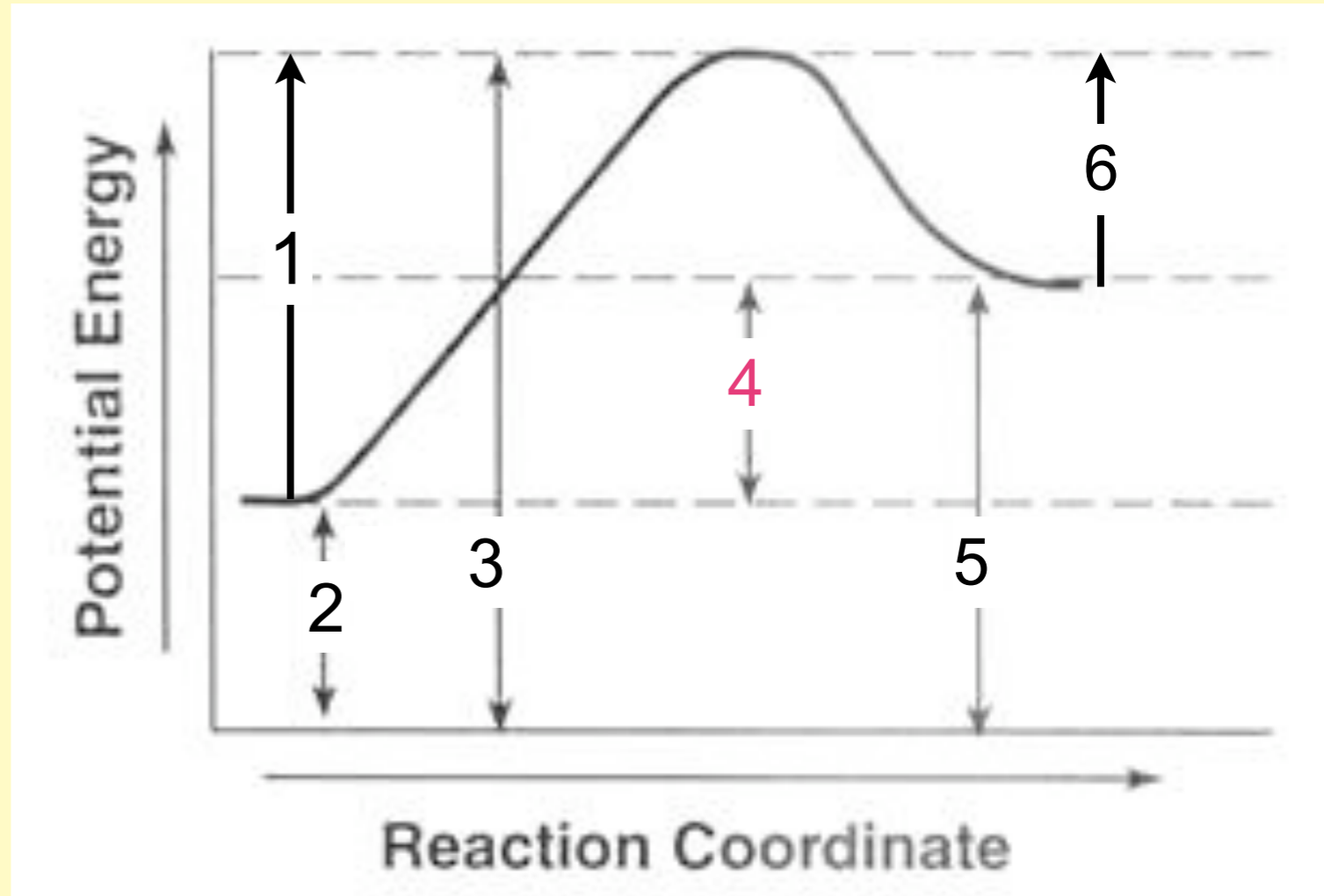

# The reaction represented by this graph

1. is exothermic
2. is endothermic
3. There is not enough information to determine the energetics of this reaction.

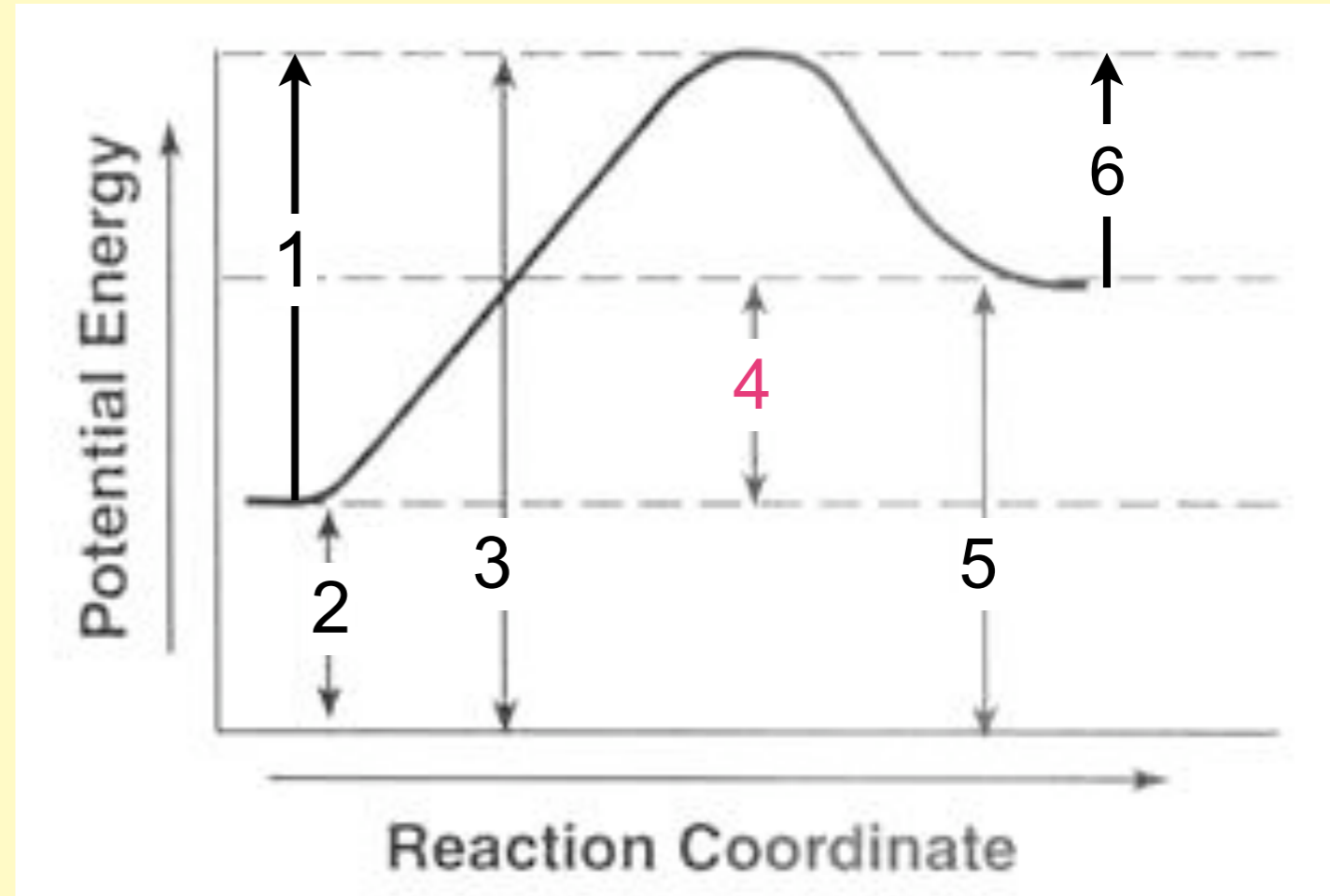

# Bond breaking

1. is exothermic
2. is endothermic
3. depends on the reaction

# Bond breaking

1. is exothermic

2. is *always* endothermic

3. depends on the reaction

- A chemical bond is a stable arrangement of electrons shared between the bonded atoms. Therefore a bond cannot be broken without the input of energy.

# If bond breaking is endothermic, bond forming

1. is exothermic
2. is endothermic
3. depends on the reaction

# If bond breaking is endothermic, bond forming

1. is exothermic

2. is endothermic

3. depends on the reaction

- When a chemical reaction occurs, bonds must be broken, and other bonds must form.
- The heat of the reaction is the net result of energy in (for bonds breaking) and energy out (for bonds forming.)

Using bond energies to estimate  $\Delta H_{rx}$

Use bond energy values to estimate

the  $\Delta H$  for  $H_{2(g)} + \frac{1}{2}O_{2(g)} \rightarrow H_2O_{(g)}$

1. Take an inventory of the bonds breaking (endothermic) and look up bond energy values.
2. Take an inventory of the bonds forming (exothermic) and look up bond energy values.
3. bonds breaking – bonds forming =  $\Delta H$

# Using bond energies to estimate $\Delta H_{rx}$

## Use bond energy values to estimate

## the $\Delta H$ for $H_{2(g)} + \frac{1}{2}O_{2(g)} \rightarrow H_2O_{(g)}$

- Take an inventory of the bonds breaking and bonds forming
- $H-H + \frac{1}{2}(O=O) - 2(H-O)$
- $[436 + \frac{1}{2}(495)] - [2(463)] = -242 \text{ kJ}$
- If you look up the heat of formation,  $\Delta H^{\circ}_f$  for this reaction, you'll get
  - $\Delta H^{\circ}_f = -241.82 \text{ kJ/mol} \dots$ nearly the same

# Use the bond energies to estimate $\Delta H_{\text{comb}}$ for the burning of propane.

1. Take an inventory of the bonds breaking (endothermic) and look up bond dissociation energy values.
2. Take an inventory of the bonds forming (exothermic) and look up bond dissociation energy values.
3. bonds breaking – bonds forming =  $\Delta H$ 
  - bond dissociation values of reactants – bond dissociation values of the products.

# Use the bond energies to estimate $\Delta H_{\text{comb}}$ for the burning of propane.

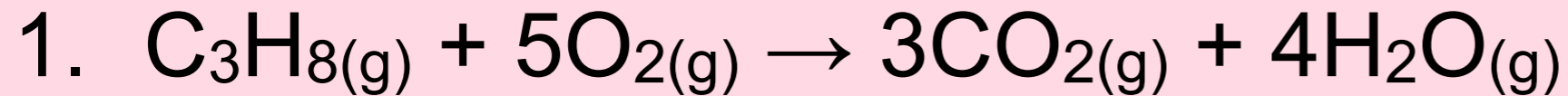

2. bonds breaking

- $2 \times \text{C}-\text{C}(348) + 8 \times \text{C}-\text{H}(413) + 5 \times \text{O}=\text{O}(495)$

3. bonds forming

- $6 \times \text{C}=\text{O}(799) + 8 \times \text{O}-\text{H}(463)$

4. breaking – forming using bond energy values

- $\Delta H_{\text{comb}} = -2,023 \text{ kJ/mol propane}$

5. calculate  $\Delta H_{\text{comb}}$  using  $\Delta H^{\circ}_{\text{f}}$  values

- $\Delta H_{\text{rx}} = \sum n \Delta H^{\circ}_{\text{f products}} - \sum n \Delta H^{\circ}_{\text{f reactants}}$

- $\Delta H_{\text{comb}} = -2044 \text{ kJ/mol propane....pretty close to the previous calc}$

- What might be causing the difference?

- the fact that bond dissociation values are averages and not exact values for the molecules in the reaction. Bonds are affected by its neighbors.

For the reaction represented by the potential energy diagram below, the total bond dissociation energy of the products (C + D) is \_\_\_\_\_ the bond dissociation energy of the reactants (A + B).

1. greater than
2. less than
3. the same as
4. none of the above, because this cannot be determined from this graph.

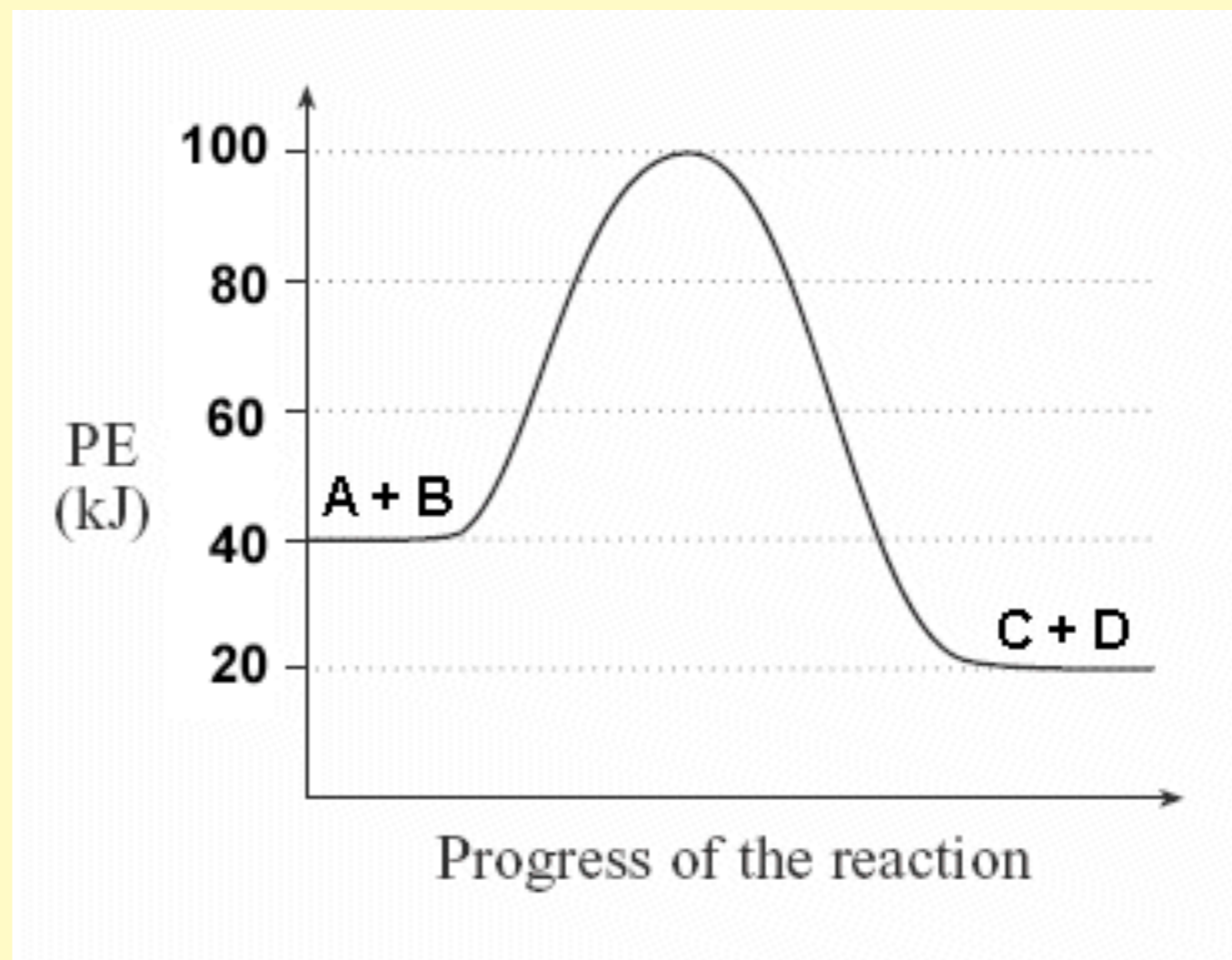

For the reaction represented by the potential energy diagram below, the total bond dissociation energy of the products (C + D) is \_\_\_\_\_ the bond dissociation energy of the reactants (A + B).

1. greater than
2. less than
3. the same as
4. none of the above, because this cannot be determined from this graph.

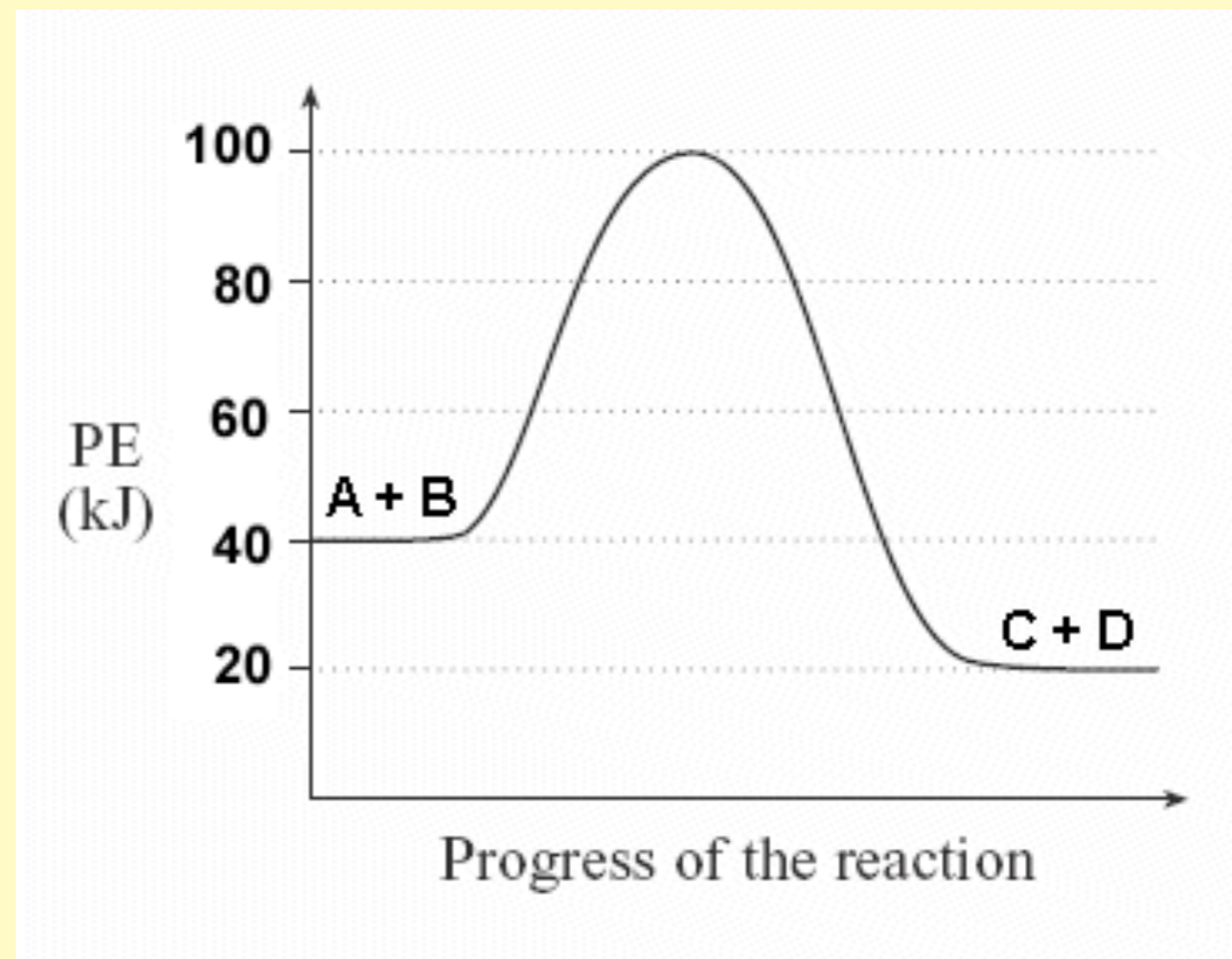

- We know this because there is more energy produced by the formation of the products than needed to break the reactants.

The heat of formation for liquid benzene is represented below

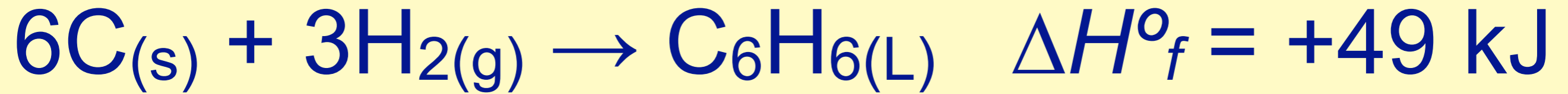

The  $\Delta H^\circ_f$  for gaseous benzene is

1. greater positive value
2. smaller positive value
3. more likely to be negative
4. unable to determine

The heat of formation for liquid benzene is represented below

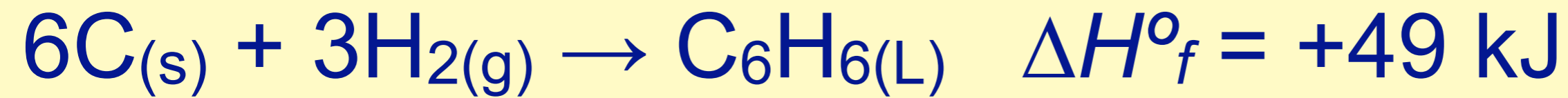

The  $\Delta H^\circ_f$  for gaseous benzene is

1. greater positive value

• you could use Hess' Law to consider this...



2. smaller positive value

3. more likely to be negative

4. unable to determine

Consider the following thermochemical equation:



The  $\Delta H^\circ_f$  for liquid water is

1.  $(+570)^2$

5.  $\frac{-570}{2}$

2.  $(-570)^2$

6.  $-570$

3.  $(+570)^{1/2}$

7.  $+570$

4.  $(-570)^{1/2}$

8.  $\frac{+570}{2}$

Consider the following thermochemical equation:



The  $\Delta H^\circ_f$  for liquid water is

1.  $(+570)^2$

7.  $+570$

2.  $(-570)^2$

8.  $\frac{+570}{2}$

3.  $(+570)^{1/2}$

4.  $(-570)^{1/2}$

5.  $\frac{-570}{2}$

6.  $-570$

- When you take the thermochemical value out of the equation above, because it is exothermic, you need to represent it as negative.
- In addition,  $\Delta H^\circ_f$  values are always per mole of whatever is being formed from its elements.

# Which energy diagram below best represents the formation of liquid water?

1.

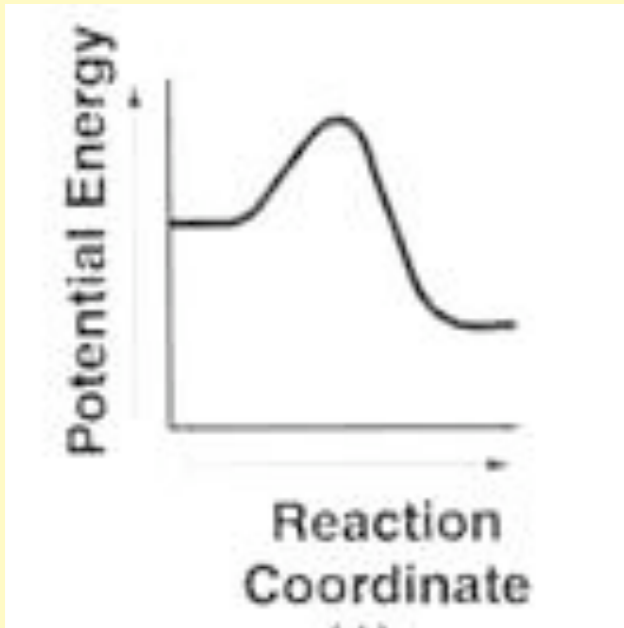

3.

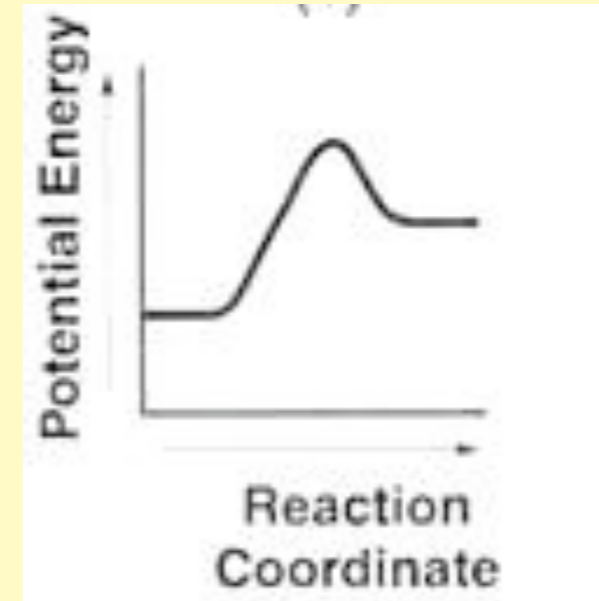

2.

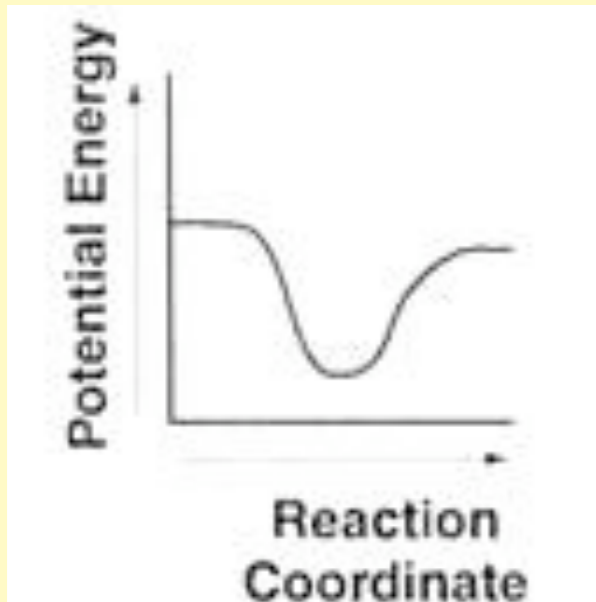

4.

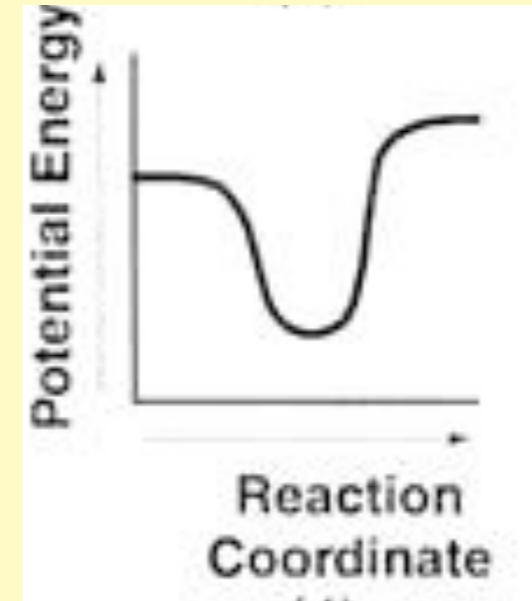

5. None of the choices are valid.

# Which energy diagram below best represents the formation of liquid water?

1.

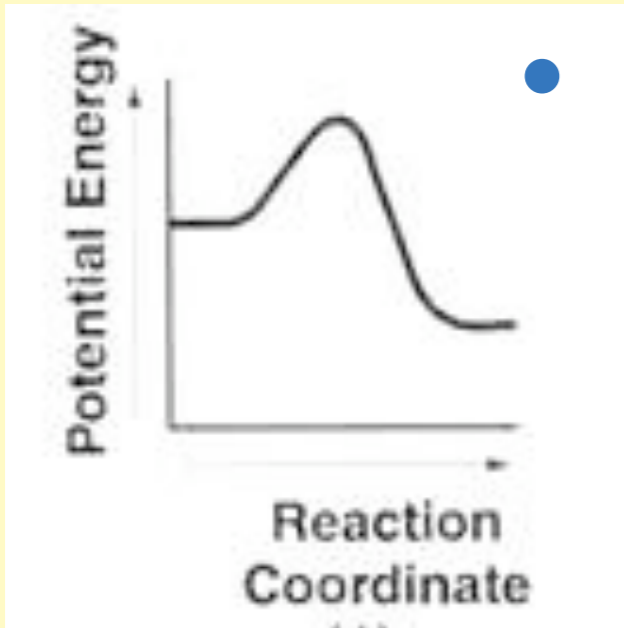

since we learned in the last slide that the formation of liquid water is exothermic.

3.

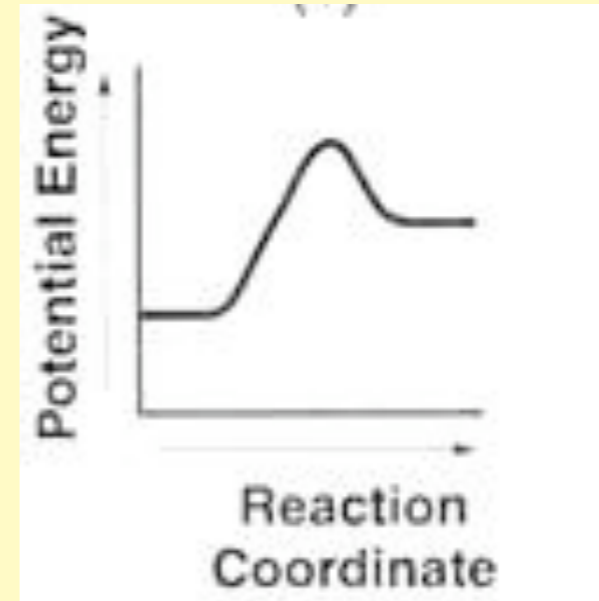

2.

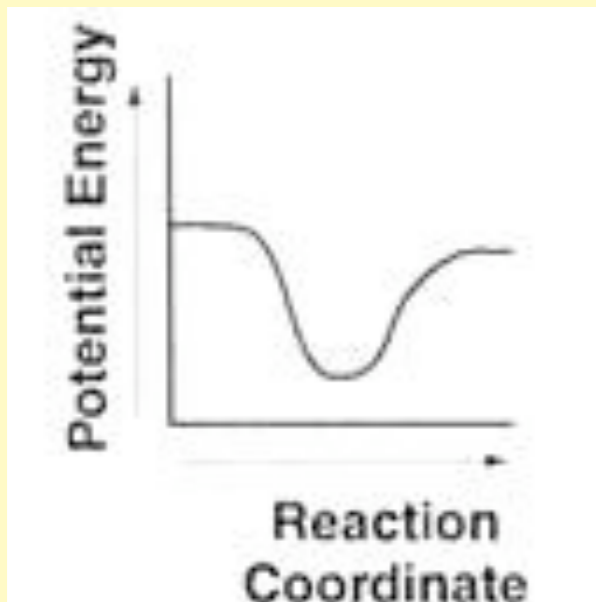

4.

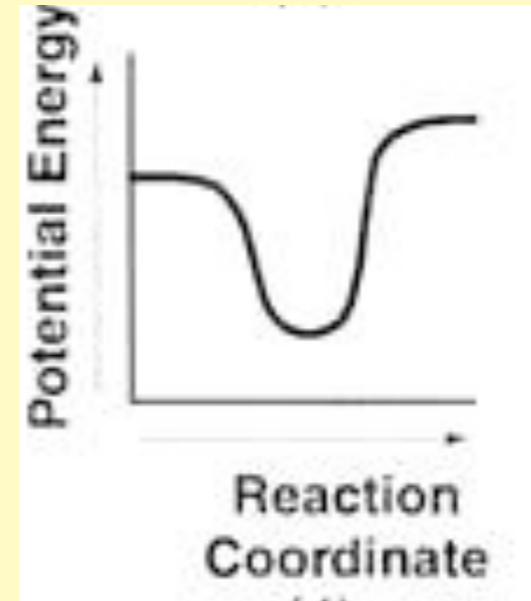

5. None of the choices are valid.

Use your Thermodynamic Tables to calculate the  $\Delta H$  for the process of vaporizing solid iodine,  $I_2$

Input your numeric answer.

Use your Thermodynamic Tables to calculate the  $\Delta H$  for the process of vaporizing solid iodine,  $I_2$



$$\Delta H_{vap} = \sum n \Delta H^{\circ}_{f \text{ products}} - \sum n \Delta H^{\circ}_{f \text{ reactants}}$$

$$+62.25 \text{ kJ/mole} - 0 \text{ kJ/mole}$$

$$\text{thus } \Delta H_{vap} = +62.25/\text{mole } I_{2(s)}$$

# Temperature *(select all that apply)*

1. is a measure of activation energy
2. is proportional to average kinetic energy
3. is heat
4. tell us hotness vs coldness
5. is proportional to molecular velocity
6. tells us the direction that heat will flow

# Temperature *(select all that apply)*

1. is a measure of activation energy
2. is proportional to average kinetic energy
3. is heat
4. tell us hotness vs coldness
5. is proportional to molecular velocity
6. tells us the direction that heat will flow

# Heat vs Temperature

- Heat and temperature are not the same thing.
- Heat is thermal energy that is transferred from a hotter object to a colder one.
- Temperature is a property that reflects the random motions of the particles of a particular substance.
  - \* Temp is directly proportional to Kinetic Energy
  - \*  $T \propto KE = \frac{1}{2}mv^2$

Use your Thermo Tables, and the enthalpy for the reaction given below to calculate the  $\Delta H^\circ_f$  for gaseous propanol.

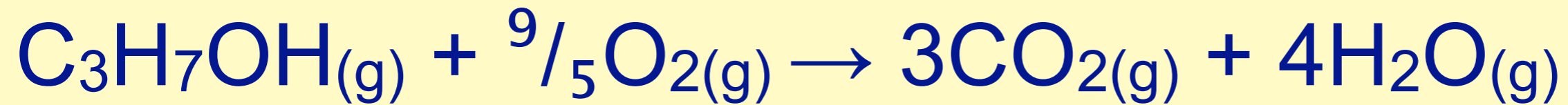

$$\Delta H_{\text{combustion}} = -2061 \text{ kJ/mole alcohol}$$

Enter a value rounded to the nearest whole number.

Use your Thermo Tables, and the enthalpy for the reaction given below to calculate the  $\Delta H^\circ_f$  for gaseous propanol.

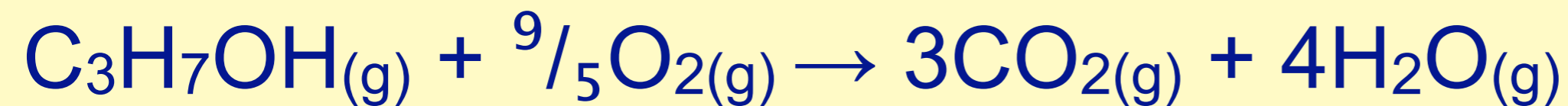

$$\Delta H_{\text{combustion}} = -2061 \text{ kJ/mole}$$

- $\Delta H_{\text{rx}} = \sum n\Delta H^\circ_f \text{ products} - \sum n\Delta H^\circ_f \text{ reactants}$
- $[3(-393.5) + 4(-241.82)] - [(x) + (0)] = -2061 \text{ kJ}$
- $x = H^\circ_f \text{ for } \text{C}_3\text{H}_7\text{OH}_{(g)} = -87 \text{ kJ}$

Which reaction best represents the  $\Delta H^\circ_f$  reaction for solid sodium nitrate?

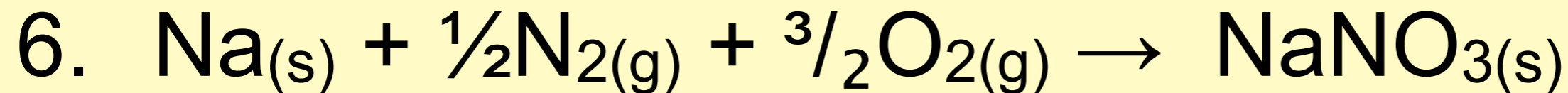
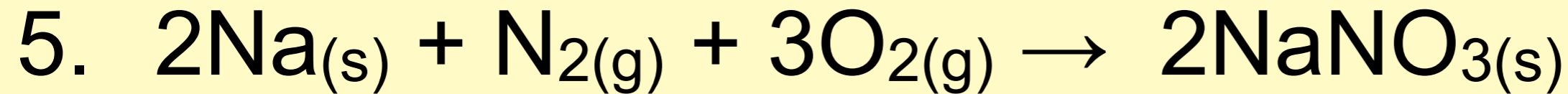
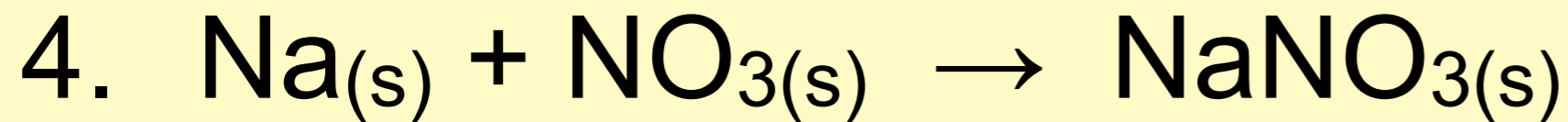
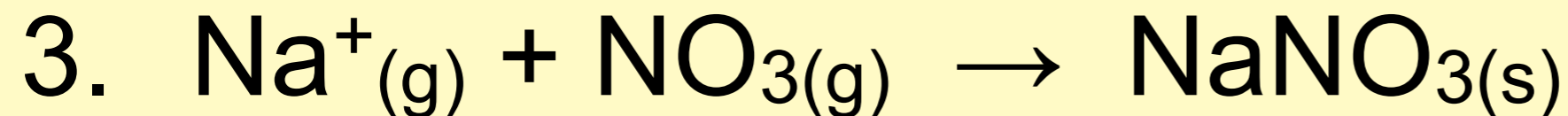
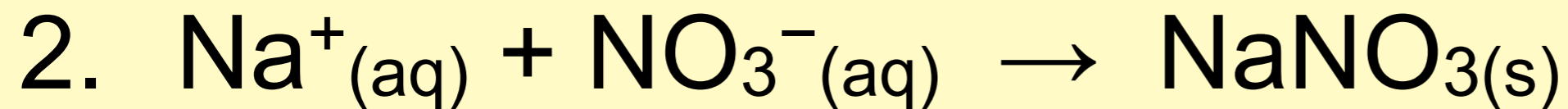
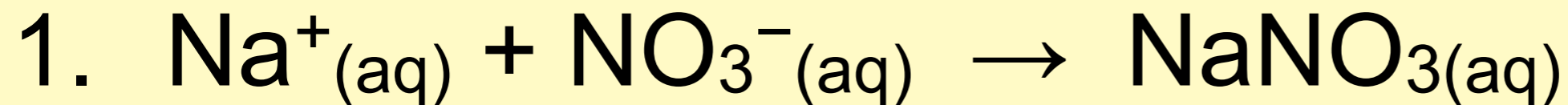

Which reaction best represents the  $\Delta H^\circ_f$  reaction for solid sodium nitrate?

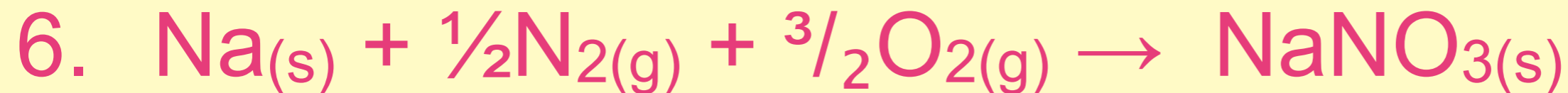
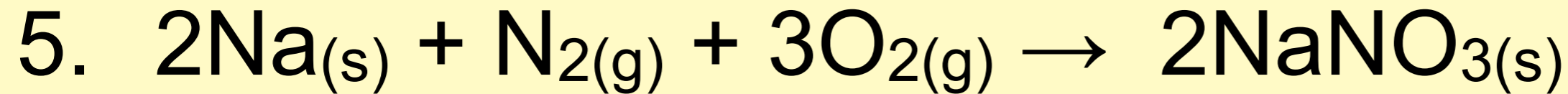
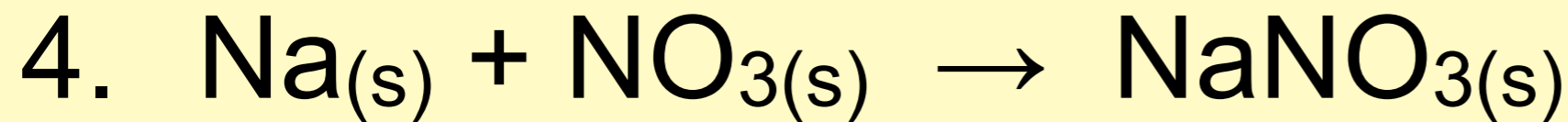
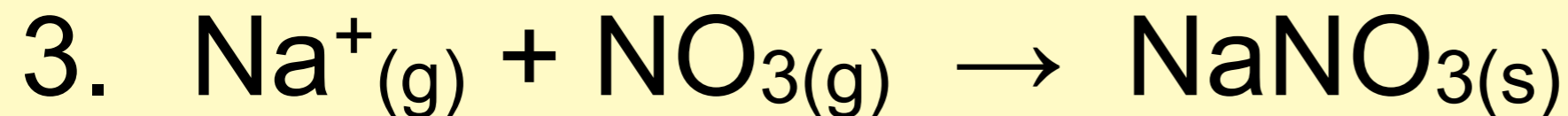
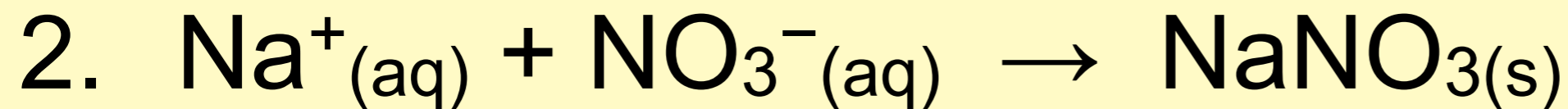
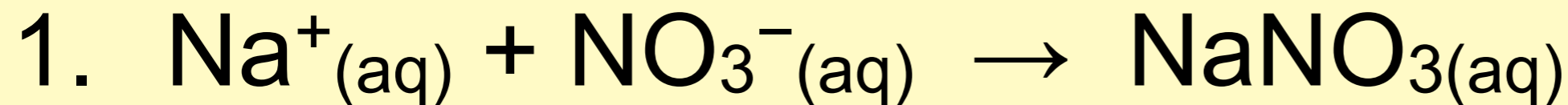

- Heat of formation reactions are always per more of the “formed” chemical.

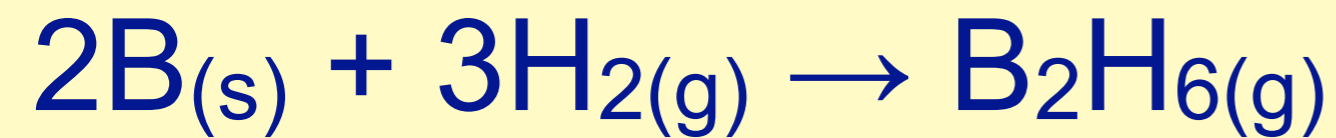

Use the reactions below to determine the  $\Delta H$  for formation of diborane shown above.

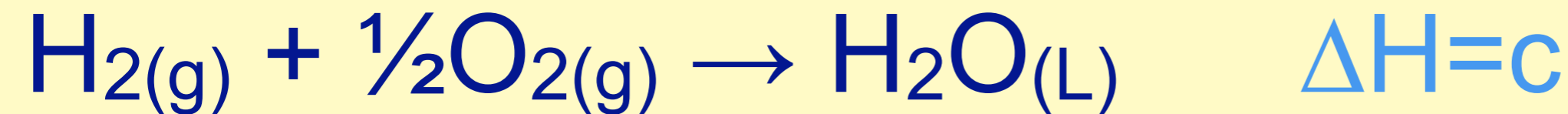
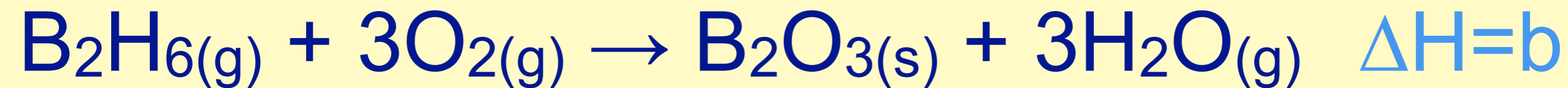
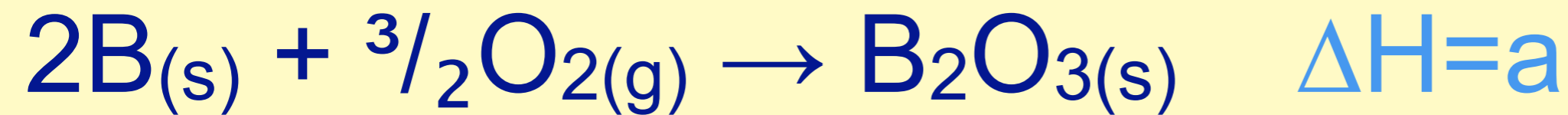

1.  $a + b + c + d$

2.  $a - b + 3c$

3.  $a - b + 3c + 3d$

4.  $b - a + c^3$

5.  $b - a + 3d$

6.  $b - a - 3c - 3d$

7. some other sum  
not listed above

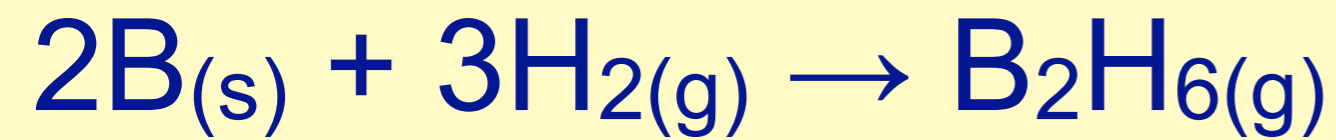

Use the reactions below to determine the  $\Delta H$  for formation of diborane shown above.

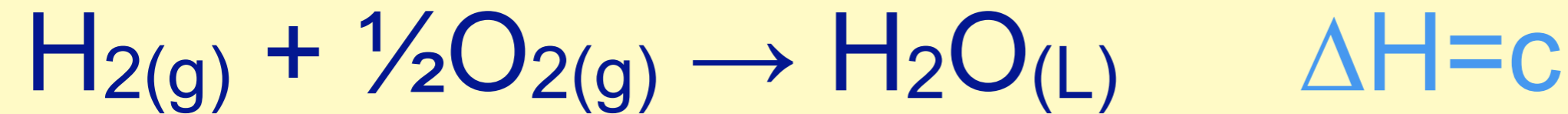
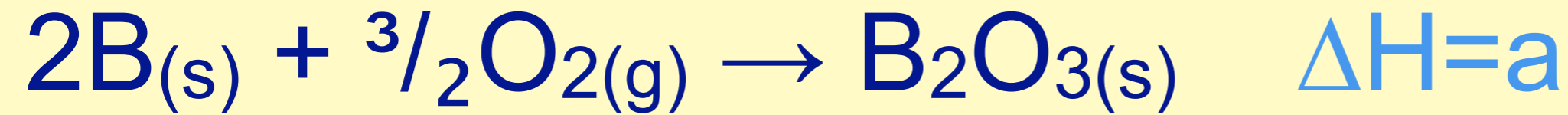

1.  $a + b + c + d$

2.  $a - b + 3c$

3.  $a - b + 3c + 3d$

4.  $b - a + c^3$

5.  $b - a + 3d$

6.  $b - a - 3c - 3d$

7. some other sum  
not listed above

Select the unit label(s) that would be appropriate for *specific* heat capacity, *c* (lower case *c*)

1.  $J$

2.  $\frac{J}{g}$

3.  $\frac{kJ}{mol}$

4.  $\frac{kJ}{K \times mol}$

5.  $\frac{J}{g \times ^\circ C}$

6.  $\frac{J}{^\circ C}$

7.  $\frac{cal}{g \times ^\circ C}$

8.  $\frac{BTU}{pound \times ^\circ F}$

Select the unit label(s) that would be appropriate for *specific* heat capacity, *c* (lower case *c*)

1.  $J$

2.  $\frac{J}{g}$

3.  $\frac{kJ}{mol}$

4.  $\frac{kJ}{K \times mol}$

Any energy unit per amount per degree would work

5.  $\frac{J}{g \times ^\circ C}$

6.  $\frac{J}{^\circ C}$

7.  $\frac{cal}{g \times ^\circ C}$

8.  $\frac{BTU}{pound \times ^\circ F}$

Select the unit label(s) that would be appropriate for heat capacity

1. J

2. J/g

3. kJ/mole

4. J/°C

5. J/g°C

Select the unit label(s) that would be appropriate for heat capacity

1. J
2. J/g
3. kJ/mole
4. J/°C
5. J/g°C

## Heat Capacity

The amount of energy required to change the temperature of a substance 1°

Select the unit label(s) that would be appropriate for  $\Delta H^{\circ}_f$

1. kJ
2. kJ/mole
3. kJ/mole $^{\circ}$ C
4. J/g
5. J/ $^{\circ}$ C
6. J/g $^{\circ}$ C

Heat Capacity

The amount of energy required to change the temperature of a substance  $1^{\circ}$

Select the unit label(s) that would be appropriate for  $\Delta H^{\circ}_f$

1. kJ

2. kJ/mole

3. kJ/mole $^{\circ}$ C

4. J/g

5. J/ $^{\circ}$ C

6. J/g $^{\circ}$ C

Which metal will undergo the greatest temperature change if an equal amount of heat is added to each?

1. Fe,  $c = 0.45 \text{ J/g K}$

2. Al,  $c = 0.90 \text{ J/g K}$

3. Cu,  $c = 0.38 \text{ J/g K}$

4. Pb,  $c = 0.13 \text{ J/g K}$

5. Sn,  $c = 0.22 \text{ J/g K}$

Which metal will undergo the greatest temperature change if an equal amount of heat is added to each?

1. Fe,  $SHC = 0.45 \text{ J/g K}$

2. Al,  $SHC = 0.90 \text{ J/g K}$

3. Cu,  $SHC = 0.38 \text{ J/g K}$

4. Pb,  $SHC = 0.13 \text{ J/g K}$

- Materials with low specific heat are easier to change their temperatures.

5. Sn,  $SHC = 0.22 \text{ J/g K}$

# Which block is hotter?

1. Bigger block
2. Smaller block
3. Same

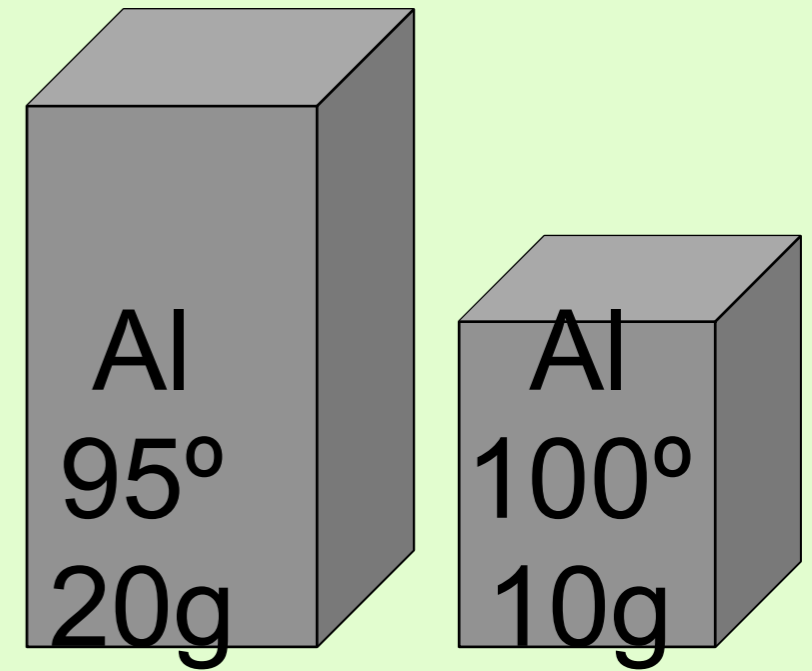

# Which block is hotter?

1. Bigger block

2. Smaller block

- temperature is a measure of “hotness/coldness.”
- It is a measure of the kinetic energy of the particles.

3. Same

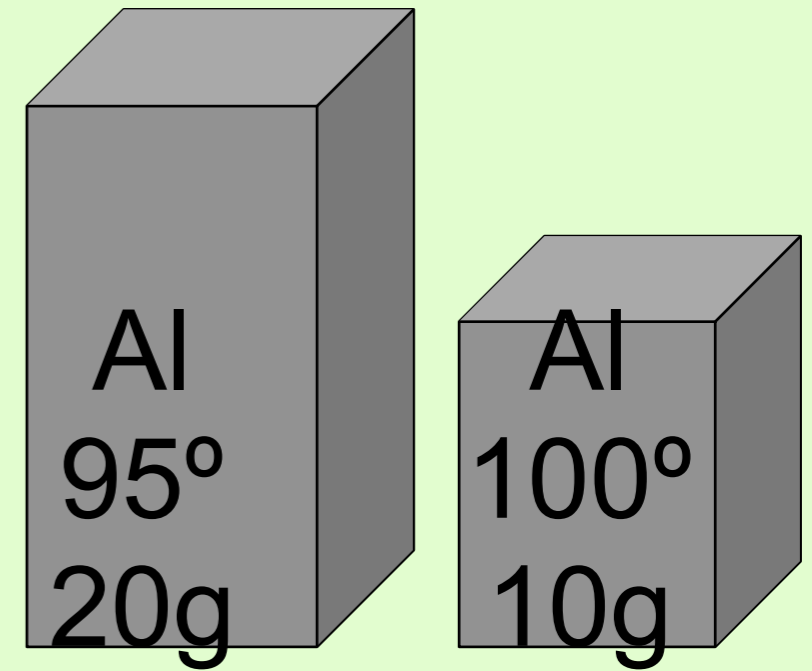

# Which block contains more heat?

1. Bigger block
2. Smaller block
3. Same

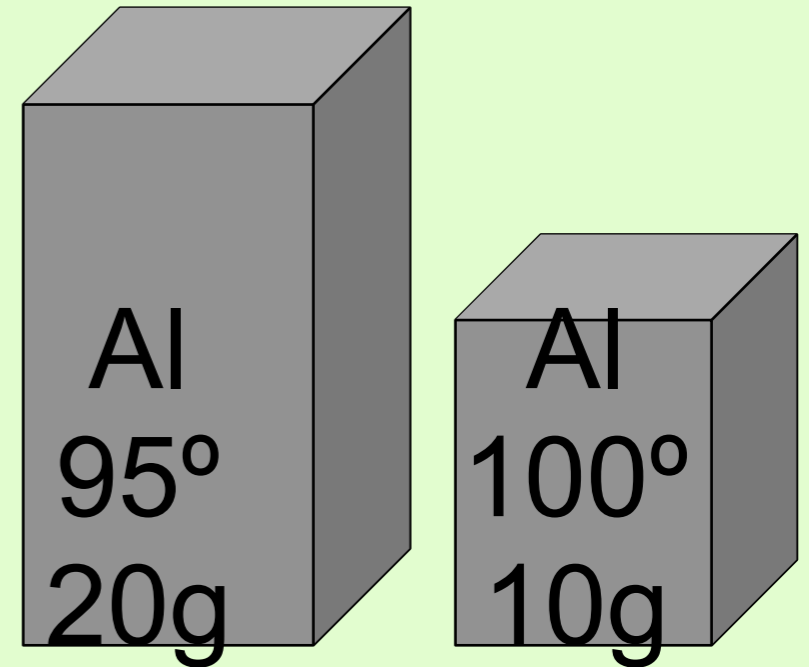

# Which block contains more heat?

## 1. Bigger block

- Even though it is at a lower temperature, the much larger mass will make for more heat capacity, thus more heat.

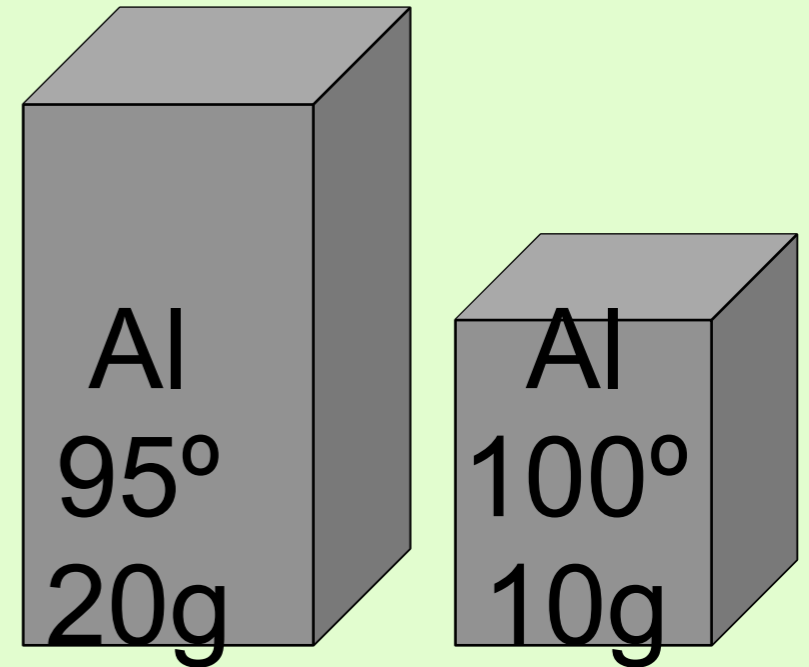

## 2. Smaller block

## 3. Same

# Which block has the higher $C_p$ ?

1. Bigger block
2. Smaller block
3. Same

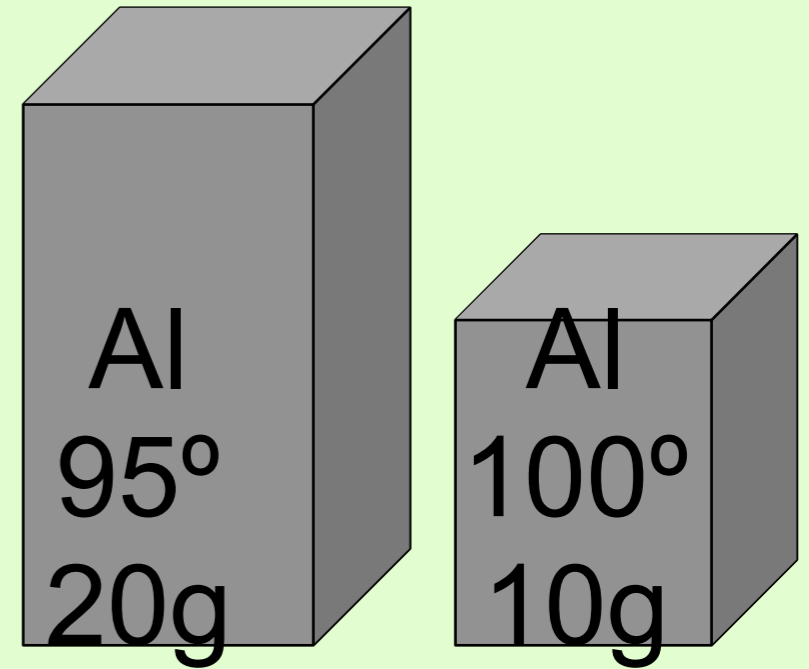

# Which block has the higher $C_p$ ?

## 1. Bigger block

- As described in the last slide, heat capacity is affected by mass.

## 2. Smaller block

## 3. Same

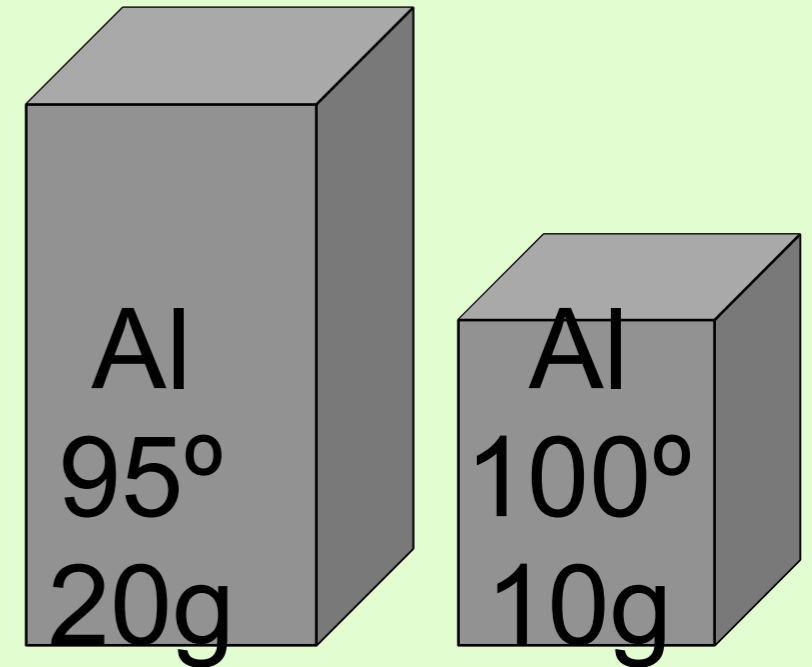

# Which block has the higher specific heat capacity, $c$ ?

1. Bigger block
2. Smaller block
3. Same

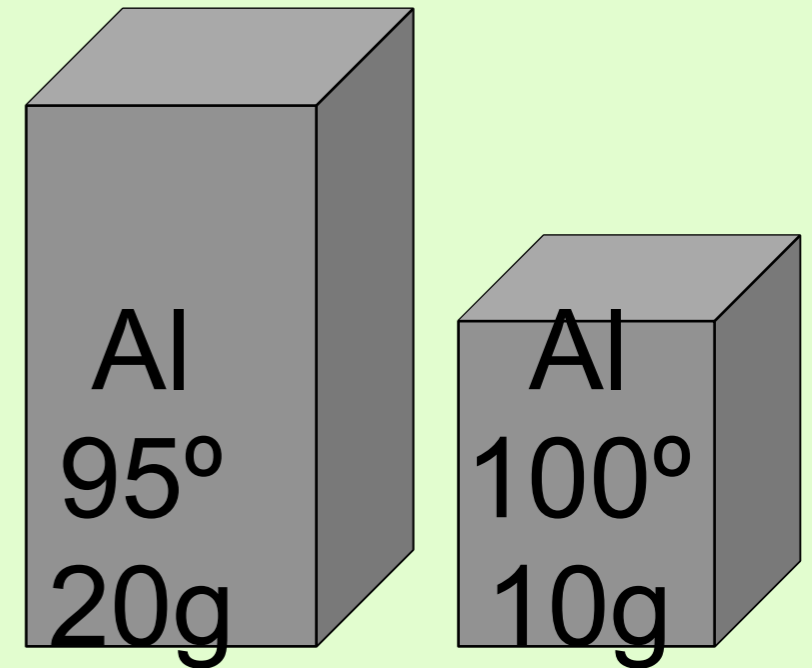

# Which block has the higher specific heat capacity, $c$ ?

1. Bigger block
2. Smaller block
3. Same
  - Specific heat capacity is an intensive property since it is heat, per degree, per amount.

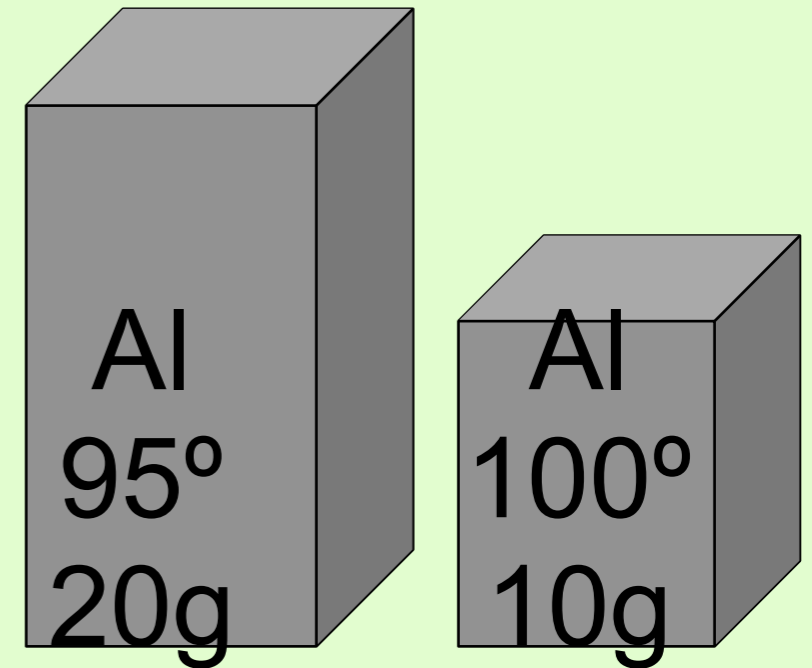

If these two blocks were allowed to come to thermal equilibrium together, would the final temp

1. Be closer to  $95^\circ$
2. Be closer to  $100^\circ$
3. Be  $97.5^\circ$
4. Be impossible to know without more information.

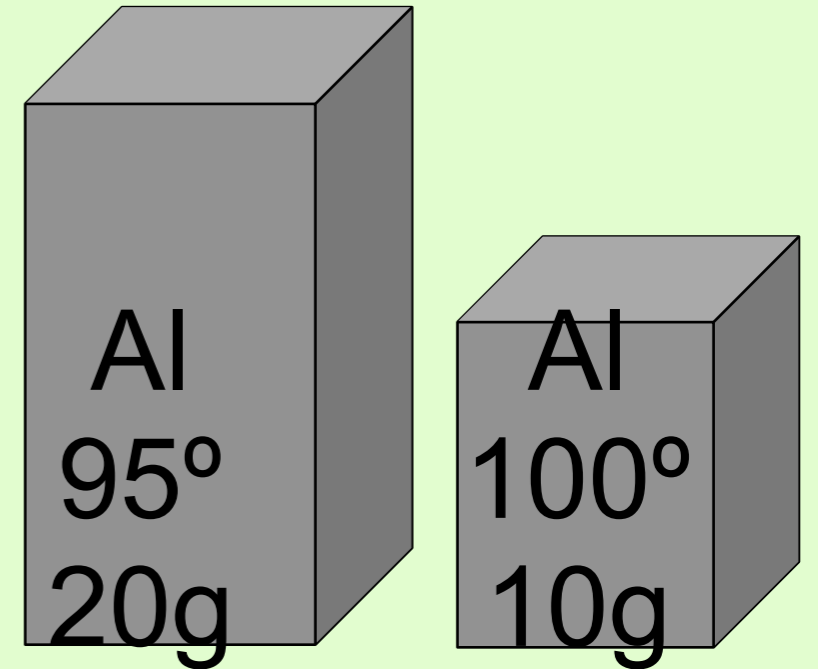

If these two blocks were allowed to come to thermal equilibrium together, would the final temp

1. Be closer to  $95^\circ$
  2. Be closer to  $100^\circ$
  3. Be  $97.5^\circ$
  4. Be impossible to know without more information.
- Write out an equation that would allow you to solve for the final temperature.

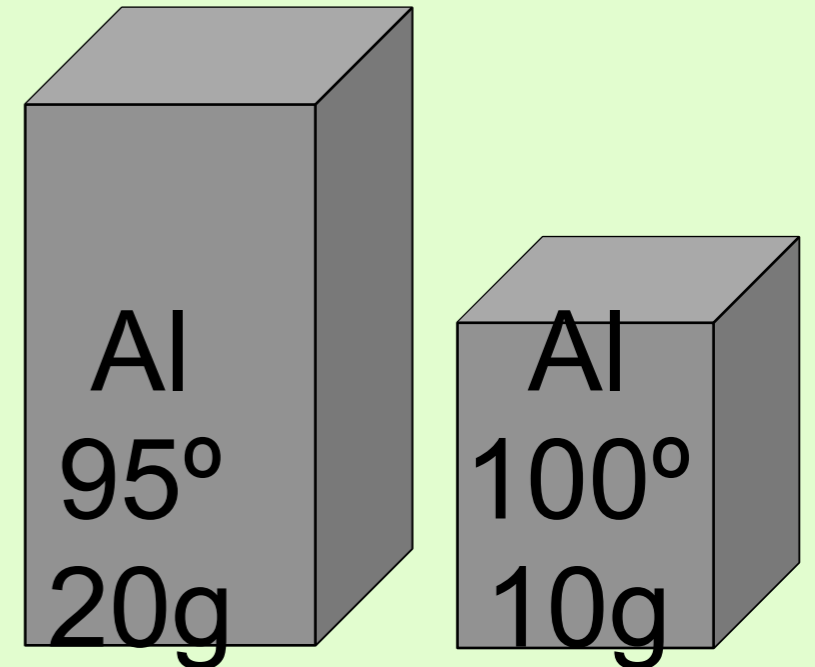

If these two blocks were allowed to come to thermal equilibrium together, would the final temp

1. Be closer to  $95^\circ$

2. Be closer to  $100^\circ$

3. Be  $97.5^\circ$

4. Be impossible to know without more information.

• Write out an equation that would allow you to solve for the final temperature.

•  $20(x-95) = 10(100-x)$

•  $x = 96.7^\circ$

